

SECTION A-A
SCALE 1 : 1.5

☒ OF SASH, FRAME, OPERATOR, & CUTOUT

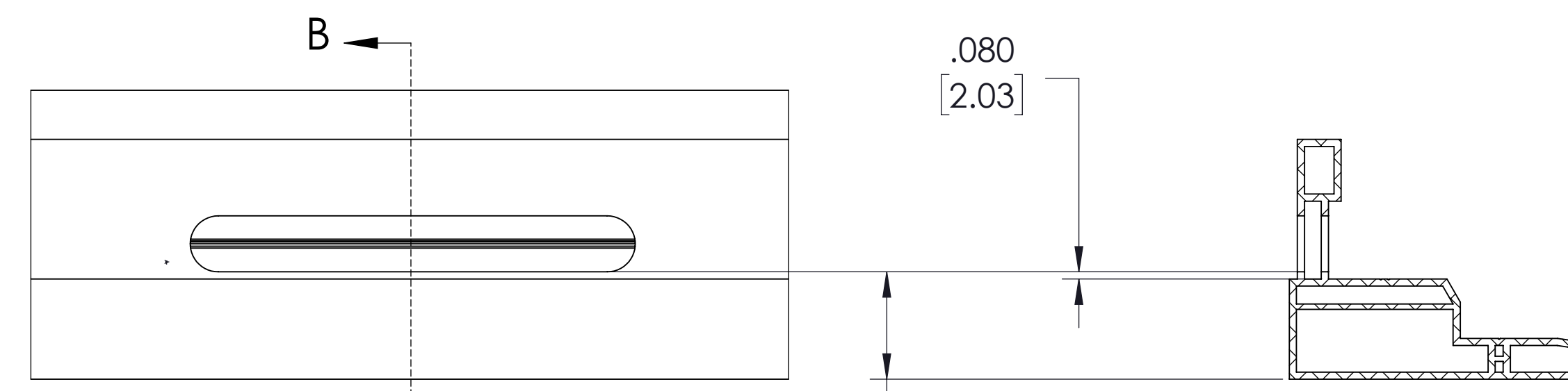

SECTION B-B
SCALE 1 : 1.5

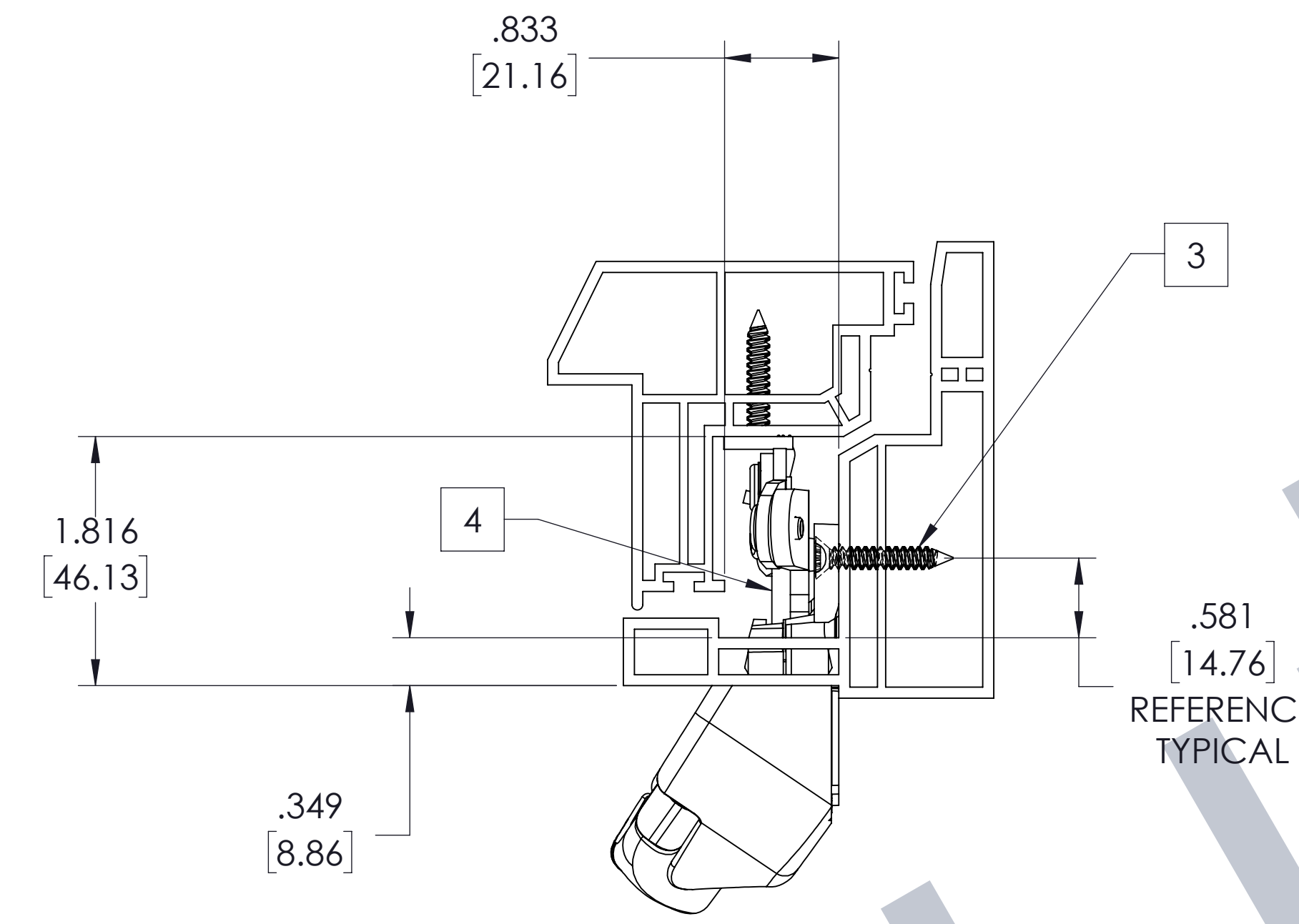

OPERATOR TRACK PLACEMENT

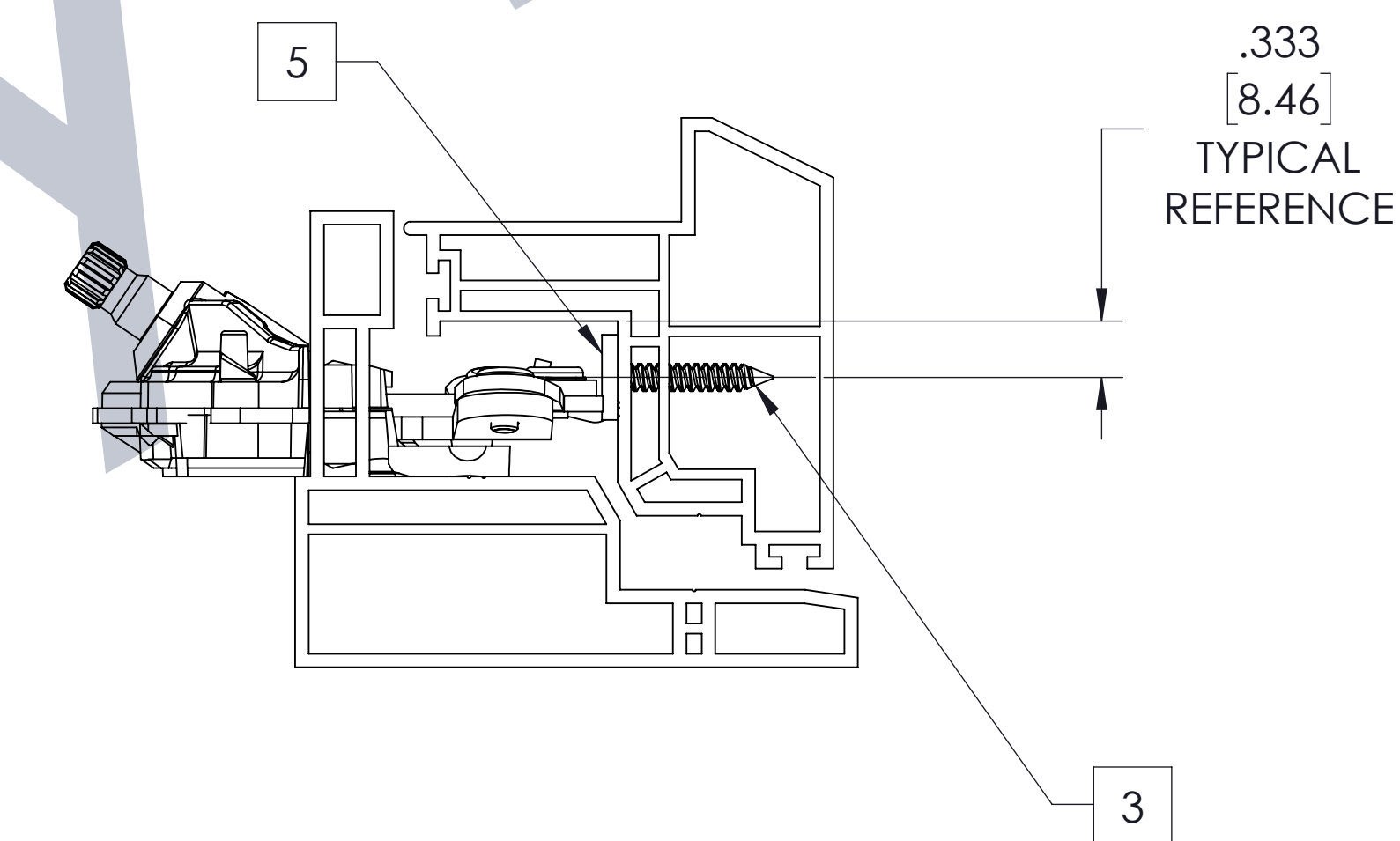

ITEM NO.	PART NUMBER	DESCRIPTION	QTY.
1	P-1496-200	COVER RH	1
2	V-1496-61	HANDLE ASSEMBLY, RH	1
3	19250	SCREW 8X1 PH FH SMS 18-8	8
4	V-1491-400	FINAL ASSEMBLY - AWNING 12'	1
5	S-1081-54	SASH BRACKET	1

